

Ampeg®

SVT-7PRO **Bass Guitar Amplifier**



Owner's Manual



TABLE OF CONTENTS

Introduction	3
Features.....	3
The Front Panel	4
The Rear Panel	6
Favorite Settings	8
Block Diagram	9
Technical Specifications	10
Warranty and Support	11

**Supplier's Declaration of Conformity
47 CFR § 2.1077 Compliance Information**

Unique Identifier: Ampeg® SVT®-7PRO

Responsible Party - U.S. Contact Information:

Yamaha Guitar Group, Inc.
26580 Agoura Road
Calabasas, CA 91302-1921
(818) 575-3600
<https://ampeg.com/>

FCC Compliance Statement:

This device complies with Part 15 of the FCC Rules. Operation is subject to the following two conditions: (1) This device may not cause harmful interference, and (2) this device must accept any interference received, including interference that may cause undesired operation.

Introduction

Congratulations! You are now the proud owner of an Ampeg SVT®-7PRO bass guitar amplifier. This no-compromise amplifier packs 1000 watts of fury, a switching power supply, and the classic good looks and features of our renowned SVT PRO Series amplifier head.

The SVT-7PRO amplifier is an ideal companion to the Ampeg SVT-410HLF, SVT-610HLF, or SVT-810E cabinet, available separately.

The switching power supply keeps the weight low, without sacrificing power output or our legendary sound quality.

Like all Ampeg products, your SVT-7PRO amplifier is designed by musicians and built using only the best of components. Each amplifier is tested to confirm that it meets our specifications, and we believe that this amplifier is the absolute best that it can be.

In order to get the most out of your new amplifier, please fully read this *Owner's Manual*, as well as the *Important Safety Instructions* included with your SVT-7PRO, before you begin playing.

And **thank you** for choosing Ampeg.

Features

- Single 12AX7A vacuum tube preamp
- Mute switch
- Selectable -15 dB Input Pad
- Dual-function Mute and Peak LED
- On-board optical Compressor
- Gain control
- Ultra Lo and Ultra Hi switches
- Bass, Mid, and Treble controls
- 5-way Midrange Frequency control
- FX Mix control
- Master Volume control
- Headphone output
- Effects Loop with separate Send and Return jacks
- Tuner Output
- XLR Tube Direct Output
- Preamp Out and Power Amp In jacks
- Footswitch jack
- Stereo RCA Auxiliary Input
- Two speakON® - 1/4" combo Speaker Output jacks
- Lightweight, fan-cooled Switching Power Supply
- Class-D power amplifier rated at 1000 Watts RMS into 4 Ω

The Front Panel

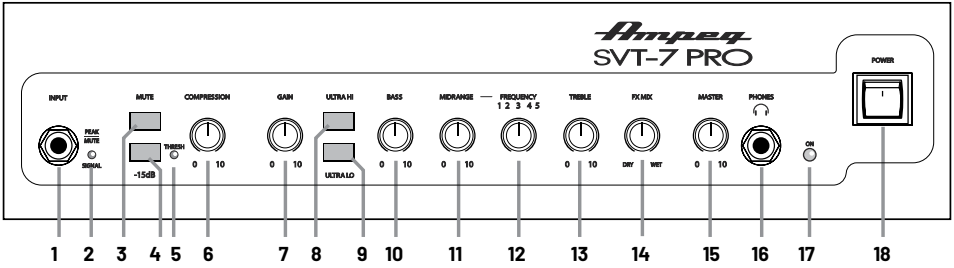

1. **INPUT:** The signal output from an instrument (active or passive) may be connected to this 1/4" Input by means of a shielded instrument cable.
2. **PEAK/MUTE LED:** This red warning LED will come on if: the Mute switch is engaged, the input signal is too high, the gain control is set too high, or there is too much boost from the Bass, Midrange and Treble controls. If it comes on regularly, even when these controls are low, try engaging the -15 dB Pad.
3. **MUTE:** Press this switch in to mute the signal. The Peak/Mute LED will illuminate when this switch is engaged.
4. **-15 dB Pad:** Press this switch in to reduce the input signal by 15 dB and compensate for higher output sources. This attenuation is suited for use with basses that have active electronics or high-output pickups. Use this Pad if you notice that the Peak/Mute LED [2] comes on regularly. It will reduce the chance of over-driving the preamplifier stage, and provide more usable range and fine adjustment of the Gain control.
5. **THRESH LED:** This lights when the signal level is above the compressor threshold, and gain reduction is active.
6. **COMPRESSION:** This controls the amount of signal compression. At the fully counter-clockwise position there is no compression; at the fully clockwise position the compression ratio is 10:1. The sonic effect of compression is reduced dynamics, increased sustain, and a more consistent output level, regardless of how light or hard the strings are played. The compressor is very transparent—that is, there is very little effect on the tone of your instrument.
7. **GAIN:** This varies the amount of signal driving the preamplifier. If a small clockwise rotation from minimum leads to overloading, and the Peak LED [2] illuminating, try engaging the -15 dB Pad [4]. This will provide more usable range with the Gain control.
8. **ULTRA HI:** This switch, when engaged, enhances the amount of high frequency output by 9 dB at 8 kHz.
9. **ULTRA LO:** This switch, when engaged, enhances the amount of low-end output by 2 dB at 40 Hz, and 10 dB cut, at 500 Hz.
10. **BASS:** Use to adjust the low frequency level of the amplifier. This provides up to 12 dB of boost, or 12 dB of cut, at 40 Hz. The low frequency output is flat at the center position.
11. **MIDRANGE:** Use this to adjust the midrange frequency level of the amplifier. This provides up to 10 dB of boost, or 20 dB of cut, at 800 Hz. The midrange frequency output is flat at the center position. Rotate the control counter-clockwise for a "contoured" sound (more distant, less midrange output), or clockwise for a sound that really cuts through.

The Front Panel - Continued

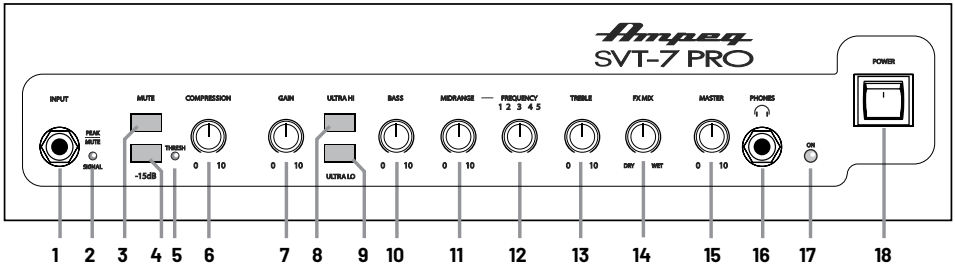

- 12. FREQUENCY SELECT:** This control allows you to select the center frequency for the Midrange control [11], giving you a choice of five frequencies for the midrange. The numbers correspond to the following center frequencies: 1=220 Hz, 2=450 Hz, 3=800 Hz, 4=1.6 kHz, and 5=3 kHz.
- 13. TREBLE:** Use to adjust the high frequency level of the amplifier. This provides up to 15 dB of boost, or 20 dB of cut, at 4 kHz. The high frequency output is flat at the center position.
- 14. FX MIX:** This control varies the mix between the direct (dry) signal and the effects (wet) when the Effects Loop is used. Full counter-clockwise results in all direct signal (no effect) and full clockwise adds all effect, with no direct signal. The fully clockwise position is equivalent to a series Effects Loop and should be used with such devices as limiters and equalizers.
- 15. MASTER:** Use this to control the overall output level. It affects the speaker outputs and headphones output. Use it wisely and turn it down when making connections, putting on headphones, or trying something new.
- 16. PHONES:** Use this 1/4" TRS, stereo output to connect your headphones. The output here is the line level signal reaching the amplifier.
- The signal to the power amp is killed when headphones are connected. You do not need to disconnect the speaker cables from the speaker cabinet (but you could, if so desired).
-  Before putting on headphones, make sure the Master control [15] is turned down. This will reduce the chance of hearing damage due to loud volumes.
- 17. POWER LED:** This LED illuminates when the power is on.
- 18. POWER SWITCH:** Use this switch to turn the overall system power on or off. Press the top of the switch to turn on the power. Press the bottom of this switch turn off the power. To remove AC power, either turn off the AC mains supply, or unplug the power cord from the speaker and the AC mains supply.

The Rear Panel

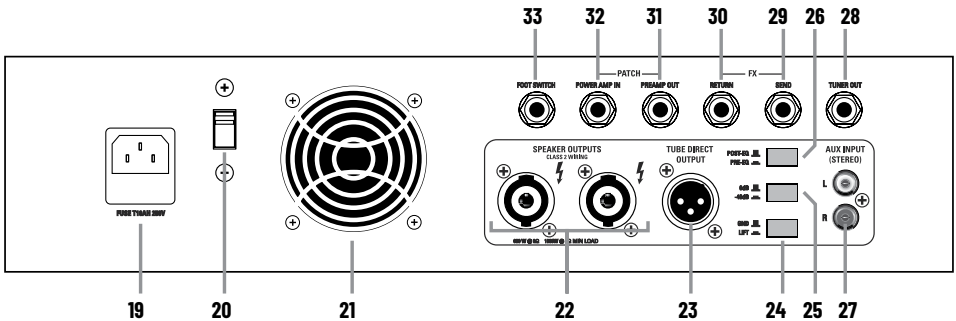

19. IEC POWER INPUT CONNECTOR: This is where you connect the supplied AC power cord.

⚠ Before plugging in the power cord, make sure that the Voltage Selector Switch [20] is set to the same voltage as your local AC mains.

20. VOLTAGE SELECTOR SWITCH: Make sure the switch is in the correct position for your local AC mains voltage before you plug in the AC power cord. Use a small flat screwdriver to slide the switch, if required.

21. VENTILATION: Make sure that the ventilation openings are not obscured in any way. This will allow the flow of air to cool the power amplifier's heatsinks.

22. SPEAKER OUTPUTS: These speakON / 1/4" TS output jacks supply speaker-level power to the speaker cabinet(s). The rated power output is 600 Watts RMS into 8 Ω , or 1000 Watts RMS into 4 Ω .

⚠ The two identical outputs are wired in parallel, and you can use one, or use both. Make sure the total speaker impedance load is 4 Ω or greater. For example, you could connect:

- Two 16 Ω speakers (an 8 Ω load)
- Two 8 Ω speakers (a 4 Ω load)
- One 4 Ω speaker

⚠ Use speaker cables with speakON or 1/4" TS ends to make the connections. Do not use (shielded) instrument cables as they may overheat.

23. TUBE DIRECT OUTPUT: Typically, you would connect this balanced XLR output to the balanced input of an external mixer or a recorder. In this way, you do not need to mic the speaker cabinet in order to add it to the main mix, or to record. The output is not affected by the Master control.

This output can connect to external power amplifiers, or powered loudspeakers, as long as they have their own input controls to adjust the volume level.

Balanced connections allow long cable runs to be used, as hum and noise pickup in the line is minimized.

24. GROUND / LIFT SWITCH: Press this switch in to engage the Ground Lift, if necessary, to help eliminate hum at the Tube Direct Output jack [23].

25. 0 dB (line level) / -40 dB (mic level): Press this switch in to apply a 40 dB cut to the signal at the Tube Direct Output jack [23].

The Rear Panel - Continued

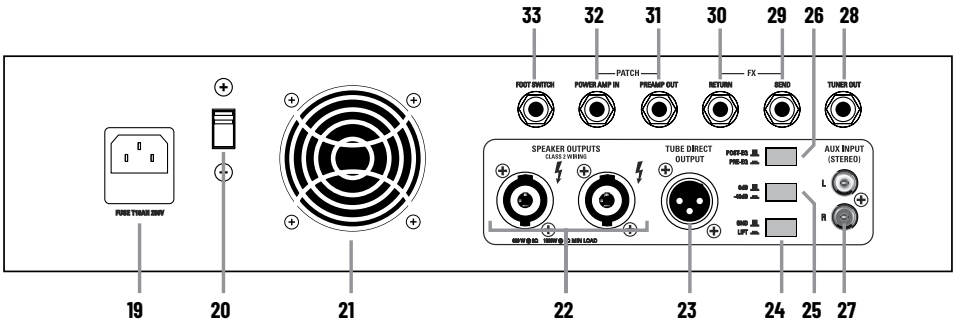

26. POST-EQ/PRE-EQ: The signal at the Tube Direct Out [23] can be set to either Pre-EQ or Post-EQ with this switch. With the switch in the "in" position, the signal at the Tube Direct Out is Pre-EQ. This is a direct output not affected by any EQ or boost settings. With the switch in the "out" position, the signal is Post-EQ and is controlled and modified by the tone controls, semi-parametric EQ, and the Effects Loop.

27. AUX INPUT (STEREO): This dual RCA jack allows you to connect external sources such as a mobile device or MP3 player. This signal comes after the FX Return, but before the Master Volume.

28. TUNER OUT: This jack supplies the only live output when the Mute switch [3] is engaged. This allows for silent tuning through an electronic tuner, or killing the house send with a monitor mixer send still active.

29. FX SEND JACK: Use this 1/4" TS unbalanced output to send a line level output to, for example, an external effects processor. The output here is affected by all controls, except the Master.

Use the FX Return jack [30] to feed the returned processed signals back into the power amplifier.

30. FX RETURN JACK: Use this 1/4" TS unbalanced input to return the processed line level output, for example, from an external effects processor. The processor could be fed by signals from the FX Send.

31. PREAMP OUT: This jack is a direct, Post-Master, Preamp Output for use with an external power amp. Connect the external amp's input to this jack using a shielded instrument cable.

32. POWER AMP IN: This jack connects directly to the SVT-7PRO internal power amp, for use with an external preamp. When using an external source, connect the OUTPUT of the source to this jack, using a shielded instrument cable, to feed the signal into the power amp section. The internal signal is disconnected when a plug is inserted into this jack.

33. FOOTSWITCH: Connect a dual footswitch to this jack for remote Mute and FX On/Off control.* On the stereo/TRS 1/4" plug, the tip controls Mute and the ring controls FX On/Off. The Mute function is available from either the front panel or the footswitch.

***NOTE:** A footswitch (model #AFP2) may be purchased from your local Ampeg Dealer, or directly from the Ampeg website, at <https://shop.ampeg.com>.

Favorite Settings

Use the following to record your own personal favorite amp settings:



MUTE	COMPRESSION	GAIN	ULTRA HI	BASS	MIDRANGE	FREQUENCY 1 2 3 4 5	TREBLE	FX MIX	MASTER
<input style="width: 40px; height: 20px;" type="text"/> <input style="width: 40px; height: 20px;" type="text"/>	<input style="width: 40px; height: 20px;" type="text"/>	<input style="width: 40px; height: 20px;" type="text"/>	<input style="width: 40px; height: 20px;" type="text"/> <input style="width: 40px; height: 20px;" type="text"/>	<input style="width: 40px; height: 20px;" type="text"/>	<input style="width: 40px; height: 20px;" type="text"/>	<input style="width: 40px; height: 20px;" type="text"/>	<input style="width: 40px; height: 20px;" type="text"/>	<input style="width: 40px; height: 20px;" type="text"/>	<input style="width: 40px; height: 20px;" type="text"/>
-15dB	0 10	0 10	ULTRA LO	0 10	0 10		0 10	DRY WET	0 10



MUTE	COMPRESSION	GAIN	ULTRA HI	BASS	MIDRANGE	FREQUENCY 1 2 3 4 5	TREBLE	FX MIX	MASTER
<input style="width: 40px; height: 20px;" type="text"/> <input style="width: 40px; height: 20px;" type="text"/>	<input style="width: 40px; height: 20px;" type="text"/>	<input style="width: 40px; height: 20px;" type="text"/>	<input style="width: 40px; height: 20px;" type="text"/> <input style="width: 40px; height: 20px;" type="text"/>	<input style="width: 40px; height: 20px;" type="text"/>	<input style="width: 40px; height: 20px;" type="text"/>	<input style="width: 40px; height: 20px;" type="text"/>	<input style="width: 40px; height: 20px;" type="text"/>	<input style="width: 40px; height: 20px;" type="text"/>	<input style="width: 40px; height: 20px;" type="text"/>
-15dB	0 10	0 10	ULTRA LO	0 10	0 10		0 10	DRY WET	0 10



MUTE	COMPRESSION	GAIN	ULTRA HI	BASS	MIDRANGE	FREQUENCY 1 2 3 4 5	TREBLE	FX MIX	MASTER
<input style="width: 40px; height: 20px;" type="text"/> <input style="width: 40px; height: 20px;" type="text"/>	<input style="width: 40px; height: 20px;" type="text"/>	<input style="width: 40px; height: 20px;" type="text"/>	<input style="width: 40px; height: 20px;" type="text"/> <input style="width: 40px; height: 20px;" type="text"/>	<input style="width: 40px; height: 20px;" type="text"/>	<input style="width: 40px; height: 20px;" type="text"/>	<input style="width: 40px; height: 20px;" type="text"/>	<input style="width: 40px; height: 20px;" type="text"/>	<input style="width: 40px; height: 20px;" type="text"/>	<input style="width: 40px; height: 20px;" type="text"/>
-15dB	0 10	0 10	ULTRA LO	0 10	0 10		0 10	DRY WET	0 10

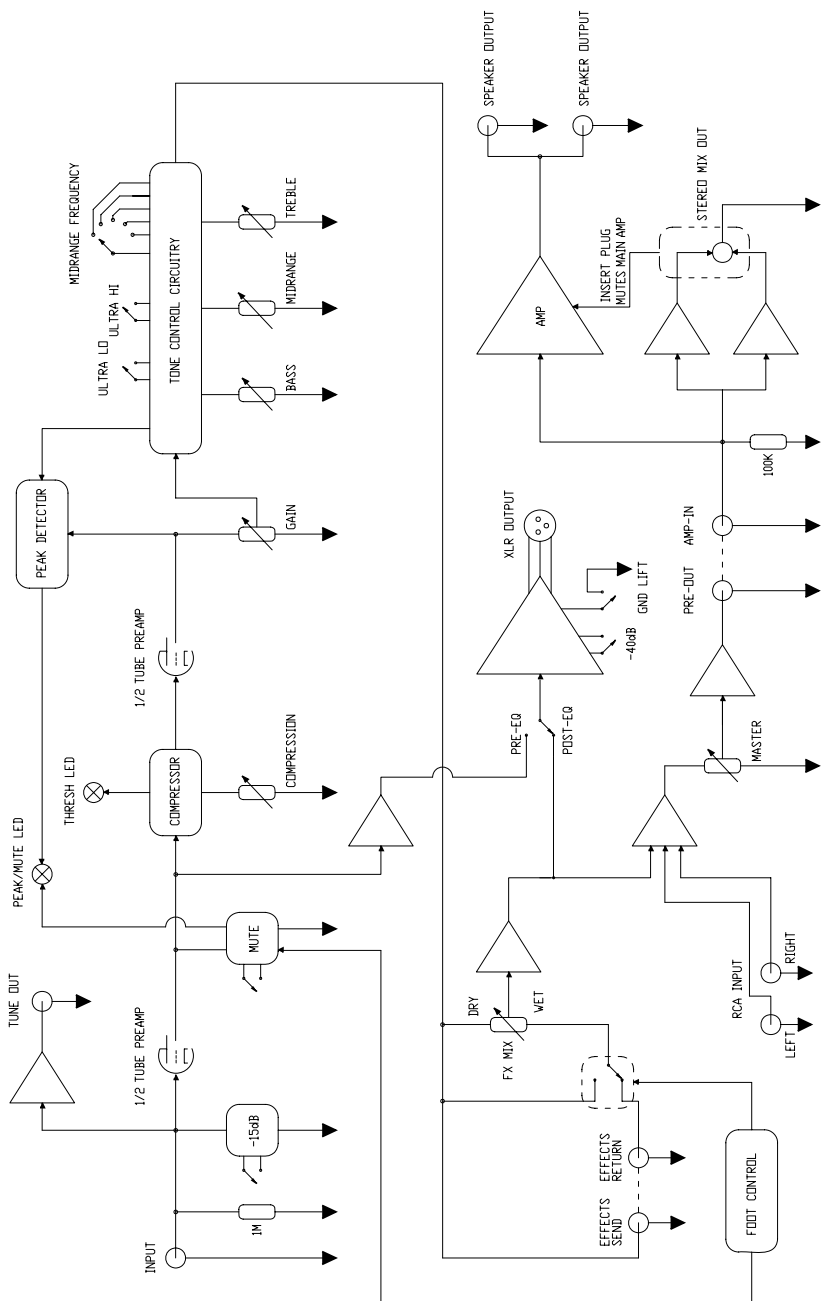

MUTE	COMPRESSION	GAIN	ULTRA HI	BASS	MIDRANGE	FREQUENCY 1 2 3 4 5	TREBLE	FX MIX	MASTER
<input style="width: 40px; height: 20px;" type="text"/> <input style="width: 40px; height: 20px;" type="text"/>	<input style="width: 40px; height: 20px;" type="text"/>	<input style="width: 40px; height: 20px;" type="text"/>	<input style="width: 40px; height: 20px;" type="text"/> <input style="width: 40px; height: 20px;" type="text"/>	<input style="width: 40px; height: 20px;" type="text"/>	<input style="width: 40px; height: 20px;" type="text"/>	<input style="width: 40px; height: 20px;" type="text"/>	<input style="width: 40px; height: 20px;" type="text"/>	<input style="width: 40px; height: 20px;" type="text"/>	<input style="width: 40px; height: 20px;" type="text"/>
-15dB	0 10	0 10	ULTRA LO	0 10	0 10		0 10	DRY WET	0 10

Block Diagram

Technical Specifications

Output Power Rating	600 Watts RMS @ 8 Ω , 5% THD 1000 Watts RMS @ 4 Ω , 5% THD
Signal to Noise Ratio	72 dB (20 Hz-20 kHz, unweighted)
Maximum Gain	72 dB, tone controls centered
Tone Controls	Bass: +12/-12 dB @ 40 Hz Midrange: +10/-20 dB @ 220 Hz, 450 Hz, 800 Hz, 1.6 kHz, or 3 kHz Treble: +15/-20 dB @ 4 kHz
Power Requirements	~100-120V AC, 50-60 Hz, 1050 W ~200-240V AC, 50-60 Hz, 1050 W
Size (H x W x D)	4.0 in/102 mm (with feet) x 15.6 in/396 mm x 11.5 in/292 mm
Weight	15.5 lb/7.03 kg (approximately)

The SVT-7PRO is covered with sheet metal and aluminum, not unlike robots, spaceships, and other cool things. Clean with a dry, lint-free cloth. Never spray cleaning agents on the SVT-7PRO. Avoid abrasive cleansers which would damage the finish.

Ampeg continually develops new products and improves upon existing ones. For this reason, the specifications and information in this manual are subject to change without notice.

Warranty and Support

Visit WWW.AMPEG.COM to...

- (1) ...identify **WARRANTY** coverage provided in your local market. Please keep your sales receipt in a safe place.
- (2) ...**REGISTER** your product.
- (3) ...**CONTACT** Technical Support, or call 818-575-3600.

www.ameg.com
Yamaha Guitar Group, Inc.
26580 Agoura Road, Calabasas, CA 91302-1921 USA
Rev. B



© 2020 Yamaha Guitar Group, Inc. All rights reserved.

Ampeg, the Ampeg logo, and SVT are trademarks or registered trademarks of Yamaha Guitar Group, Inc. in the U.S. and/or other jurisdictions. speakON is a registered trademark of Neutrik AG Corporation.